



## CONTACTS AND RESOURCES

### Whitehorse City Council

To determine whether your house is included in the Heritage Overlay or whether you need a planning permit contact:

**City of Whitehorse Planning Department**  
**379-397 Whitehorse Rd, Nunawading**  
**Tel. (03) 9262 – 6303**

Further technical information and advice specifically related to how your property can be altered while retaining its heritage significance can be obtained from the Heritage Advisor at the Council. Speak to a planner at the Council to make an appointment.

### Other Contacts

As well as being able to inform you as to whether your dwelling is listed with them, the following organisations are good sources of information regarding a range of heritage matters.

<ul style="list-style-type: none"> <li>▪ <b>Heritage Victoria</b> ph: 9637 9475 <a href="http://www.heritage.vic.gov.au">www.heritage.vic.gov.au</a></li> <li>▪ <b>National Trust of Australia (Victoria)</b> ph: 9654 4711 <a href="http://www.nattrust.com.au">www.nattrust.com.au</a></li> </ul>	<ul style="list-style-type: none"> <li>▪ <b>Department for Environment &amp; Heritage</b> ph: (02) 6274 2121 <a href="http://www.deh.gov.au">www.deh.gov.au</a></li> <li>▪ <b>Aboriginal Affairs Victoria</b> ph: 9208 3333 <a href="http://www.dvc.vic.gov.au">www.dvc.vic.gov.au</a></li> </ul>
---	---

### Relevant Documents and Resources for assistance

Associated Planning documents available from Council:

1. The former City of Box Hill Heritage & Conservation Study, Andrew Ward & Associates, 1990.
2. Nunawading Heritage Awareness Study, Context, 1994.
3. City of Whitehorse Heritage Review, Allom Lovell & Associates, April 1999.
4. City of Whitehorse Heritage Review, Andrew Ward and Associates, 2001.
5. The Burra Charter: The Australia ICOMOS Charter for Places of Cultural Significance 1999.
6. Clause 22.11 of the Whitehorse Planning Scheme "Heritage Buildings and Precincts".

### Sources of local historical information:

1. History section of your local library; and
2. Historical Societies:
  - **Box Hill Historical Society Inc.**  
Heritage Centre, Box Hill Town Hall  
PO Box 268, Box Hill 3128  
Ph. 9897 4167
  - **Whitehorse Historical Society Inc.**  
Local History Room, Schwerkolt Cottage  
& Museum Complex  
Deep Creek Road, Mitcham  
PO Box 271, Mitcham 3132  
Ph. 9873 4946
  - **Burwood History Group**  
Old Burwood Primary School  
172 Burwood Highway, Burwood 3125  
Ph. 9808 5482
  - **Surrey Hills Historical Society Inc.**  
Surrey Hills Neighbourhood Centre  
157 Union Road, Surrey Hills 3127  
Ph. 9849 1161

## CHURCHILL STREET PRECINCT

### CHURCHILL STREET PRECINCT, MONT ALBERT, HO. 100

#### Purpose of these Guidelines

The purpose of these guidelines is to ensure that new work undertaken to places in the Churchill Street Precinct retain the overall qualities, which contribute to the precinct's cultural heritage significance and character.

The key objective is to protect the significant views of the streetscape and character of the area as viewed by the local community and general public.

Council will use these guidelines, as well as the advice of its Heritage Advisor, when assessing town-planning applications for development proposals within the heritage area. These Guidelines are used in conjunction with the Council's Heritage Policy (Clause 22.11 of the Whitehorse Planning Scheme) and the State Heritage Overlay (Clause 43.01 of the Whitehorse Planning Scheme).

These guidelines are also to assist owners of heritage places in determining what may be acceptable in the development of their place.

#### Properties included in the Churchill Street Precinct, Mont Albert

20-76 Churchill Street  
427-433 Elgar Road  
2 Serpentine Street

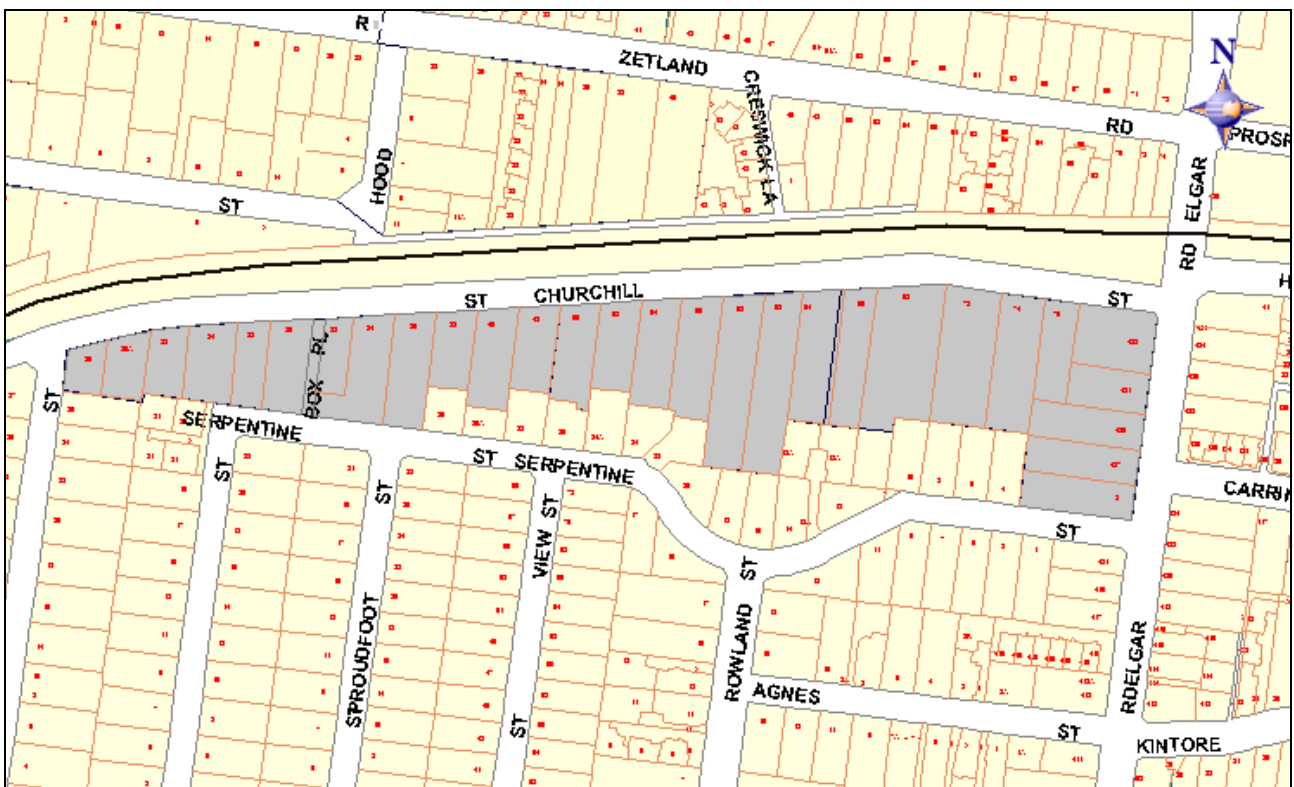

Figure 1: Boundaries of the Churchill Street Precinct

## Precincts

In Whitehorse precincts have been identified for protection in the Heritage Overlay because they typically:

- contain residential building stock predominantly from the late nineteenth century to mid-twentieth century;
- retain historically important street layouts and subdivisions;
- display consistency of scale, height and materials;
- display a stylistic consistency; and
- contain mainly historically or architecturally significant buildings which are substantially intact.

In a precinct the relationship between the buildings is just as important as the individual buildings themselves. Therefore retention of the streetscape appearance and views to enable an understanding of this relationship by the public is of prime importance.

## Churchill Street Precinct Statement of Significance

The Churchill Street Precinct is of outstanding aesthetic significance. The precinct has the most intact streetscapes of large Edwardian and inter-War houses in the City of Whitehorse. The streetscapes are characterized by a uniformity of scale, setback and materials. The houses within the precinct form an extraordinarily cohesive grouping of substantial upper middle class residences which display a wide range of interesting Arts and Crafts inspired architectural elements. The houses display a particularly high level of intactness.

## Characteristics of the precinct

- The blocks are generally very large, with relatively wide frontages.
- The housing stock in the precinct dates predominantly from the first three decades of the twentieth century.
- As a whole, the buildings display a wide range of generally Arts and Crafts influences.
- Compositionally, the houses are generally asymmetrical, with complex plan and roof forms. Gabled roof forms are common with several houses having a dominant front gable.
- Single-storey houses predominate, but they are large and many have attics, some with semi-enclosed balconies.
- All houses are constructed of brick, but most also employ a number of other materials for decorative effect. The most common roofing material is terracotta tiles.
- The landscape character of the precinct is informed both by the established private gardens, and by the street planting of plane trees in Churchill St.
- Few of the houses retain original front fences.

The style guide on the following pages outlines the characteristics of the main styles which occur within the precinct. These common characteristics between the houses contribute to the cohesive streetscape value of the precinct.

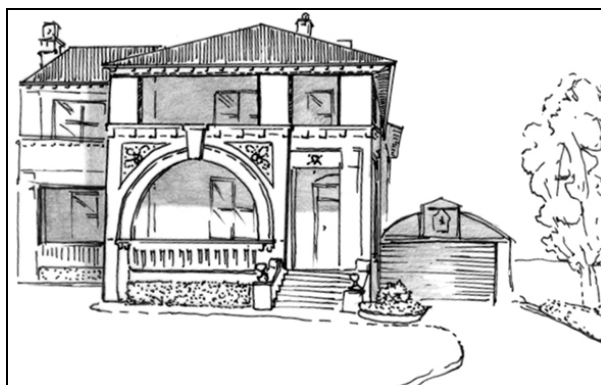

Figure 2: Federation house with Arts and Crafts detailing.

**BUILDING STYLES – EDWARDIAN / FEDERATION STYLE**

**Edwardian/Federation style key characteristics**

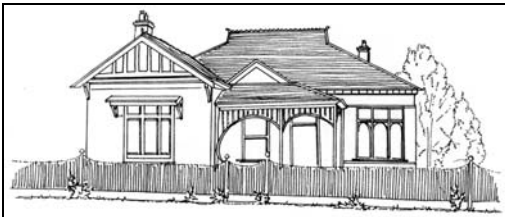

Figure 3: Edwardian

- Asymmetrical facades
- Roof often a combination of a hip and a projecting gable, usually 30 degrees pitch, and galvanized corrugated iron.
- Verandah forms included sloped or curved.
- Timber fretwork to verandah, turned or plain timber posts.
- Rectangular timber framed, double hung or casement windows, often paired or in threes.
- Four panelled front doors, commonly with highlights and sidelights.
- Decorative timber joinery around openings.
- Eaves brackets, decorative gable infill and timber brackets to window canopies.
- Chimneys – red brick, plain or with brick string courses and/or strapping.

**Federation differences**



Figure 4: Federation

- Asymmetrical with the emphasis on the overall form and three-dimensional qualities rather than the front facade.
- Focus is often on the diagonal with a projecting gable or window bay.
- Complex rooflines of intersecting hips and gables with tall chimneys.
- As well as timber walls with corrugated iron roofs, masonry or render walls with terracotta Marseilles tiled roofs.
- Leadlighting.

**Key alteration issues**

Be careful not to copy decorative details from the original dwelling in the addition as it detracts from the original details and obscures the understanding of the development of the building.

**Paint colours**

Walls of Edwardian/Federation dwellings, if painted were yellow cream, ochre wash, cement render and a greater use of browns. The predominant colour for joinery and details was red with cream, yellow ochre, dark brown and softer green trims. The exterior details were often picked out in a combination of a light and dark tone. The two predominant colour schemes for this style were shades of green or shades of cream to buff.

**Typical fence styles**

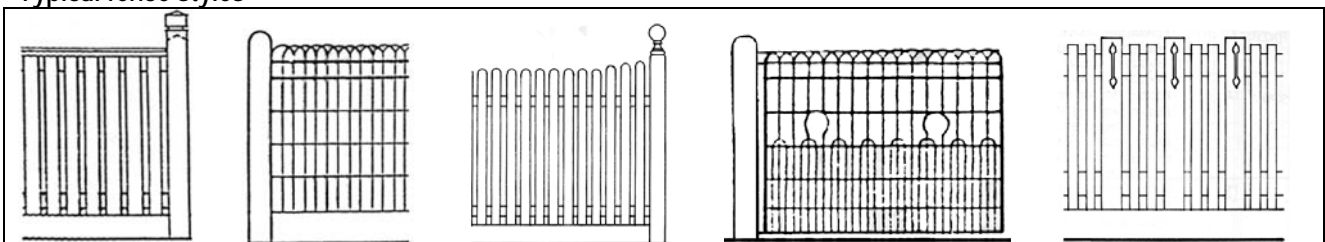

Figure 5: Typical Edwardian / Federation fence styles

## BUILDING STYLES – BUNGALOW STYLE

### Bungalow style key characteristics

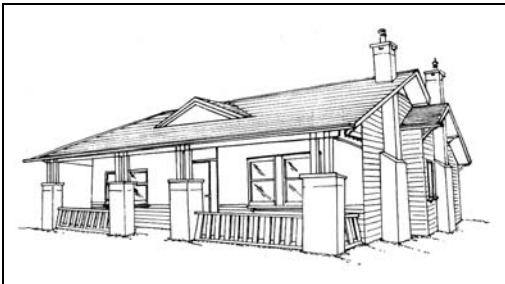

Figure 6: California Bungalow

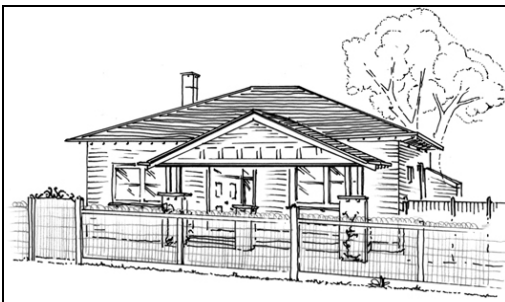

Figure 7: California Bungalow

- One or more gables, either perpendicular or parallel to the street frontage, which dominate the overall form of the building, roof usually 25 degrees or steeper.
- Emphasis on the weight of the roof, by brackets, detailing to the large gable ends, including roughcast, timber shingles and strapwork, also exposed rafter ends.
- Roofs clad in galvanized corrugated iron or tiled with cement or ceramic tiles.
- Walls often masonry and roughcast render, square edged or bull-nose weatherboards.
- Deep porches with flat roofs giving a horizontal emphasis supported by masonry pillars or grouped sturdy timber posts.
- Chimneys expressed externally as large masonry elements, face brick or roughcast with terracotta chimney pots.
- Timber framed windows often small and rectangular in form, casement or double hung with fixed panes, grouped in wide bands.
- Front doors often glazed in top section and timber below.
- Leadlight common.

### Key alteration issues

- The weight of the large tiled roofs does not easily permit the removal of load bearing walls.

### Paint colours

Exterior colour schemes of California Bungalows usually consisted of no more than two colours. Common colours for woodwork were brown, cream and green. Rendered walls had a natural slurry unpainted finish or were painted an off-white, beige or pale cream. There was often dark staining of timber rather than painting. Elaborate timberwork was not used on the exterior of these dwellings. Shingles, posts and trim were painted in the darker shade of the chosen scheme and rafters, fascia boards, bargeboards and panels were all painted in a lighter colour.

### Typical fence styles

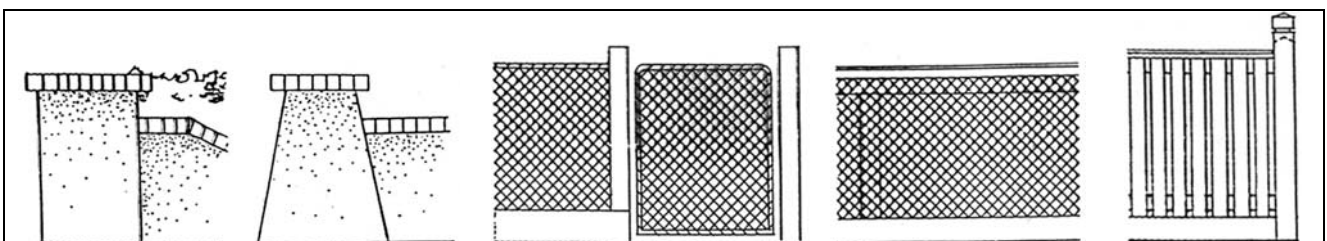

Figure 8: Typical Bungalow fence styles

**ALTERATIONS AND ADDITIONS – SITE AND PRECINCT ANALYSIS**

**Site and Building Analysis**

Before commencing a design for alterations you need to gain an understanding of the significance of your individual property, the elements which contribute to this significance, and its contribution to the streetscape value of the area. Understanding this can also assist in identifying areas of the site and building that can undergo alterations.

The first step is determining whether your building is contributory or a non-contributory building to the heritage overlay precinct.

One of the key considerations in making alterations to a dwelling within a Heritage Overlay precinct is the effect the alteration will have on the streetscape. It is the streetscape view that is often the most important element to retain and alterations should aim to minimise visual intrusion on the streetscape. Alterations should not obscure the understanding and character of a heritage area. This includes the front view of your dwelling as well as setbacks, fences and kerbs.

Consider view lines, which need to be protected to ensure the contributory elements of the place and adjoining properties, are not obscured.

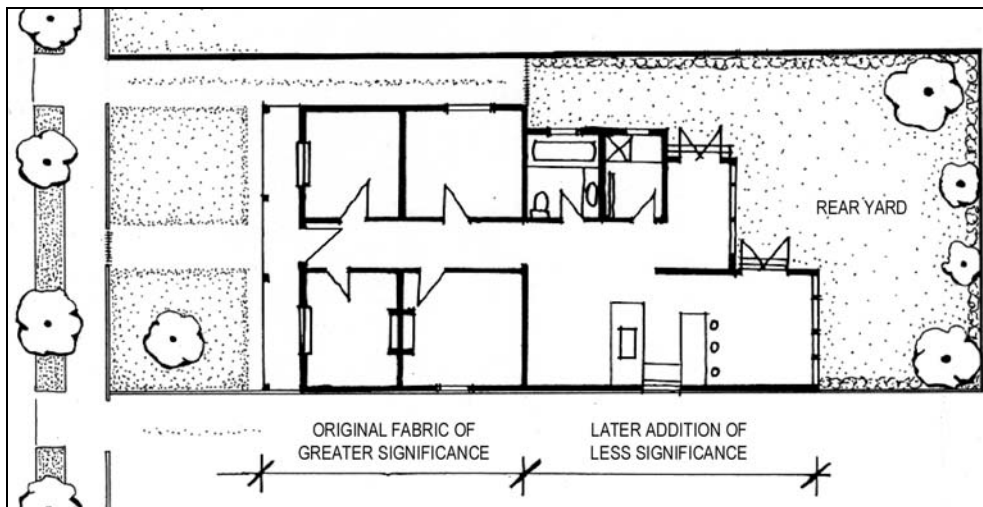

Figure 9: Identifying areas for adaptation

The aim should be to retain the character of the streetscape.

## ALTERATIONS AND ADDITIONS – VISIBILITY OF ADDITIONS

### Visibility of alterations

Alterations to the front appearance of the building and significant roofline (visible from the street) should be avoided. Additions should have minimum visibility from the street. View lines need to be protected to ensure the contributory elements of the place and adjoining properties are not obscured.

Assessing the visibility of proposed additions from the street is one technique used to determine the likely impact a proposal will have on the significance of a building and heritage area. Where works are of negligible or no visibility from the street, they are considered to have little impact on the significance of the streetscape.

The viewing lines in plan and elevation establish a suitable area for the addition from the heritage perspective. Normal building and planning permit requirements, such as boundary setbacks will also apply.

### Side views

To determine the appropriate building envelope for an addition, which minimises visibility from the street, undertake the following and refer to Figure 10

- accurately draw your dwelling and adjacent properties in plan noting setbacks.
- draw view lines from standing positions in the street past adjacent properties into your property.

This will give an area of the site available for an addition that will minimise visibility from the street.

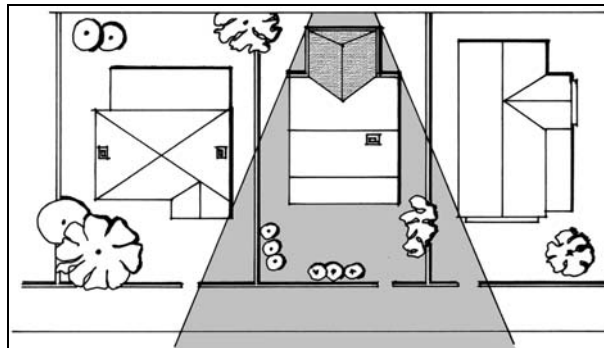

Figure 10: Determines side sight lines

### Height views.

To determine the appropriate height of an addition, which minimises visibility from the street, undertake the following and refer to Figure 11:

- accurately draw your dwelling and street in section noting heights of the existing building.
- draw view lines from eye level in the street over your existing roof form and to the rear of your property.

This will give an appropriate height for a second storey Addition that will minimise visibility from the street.

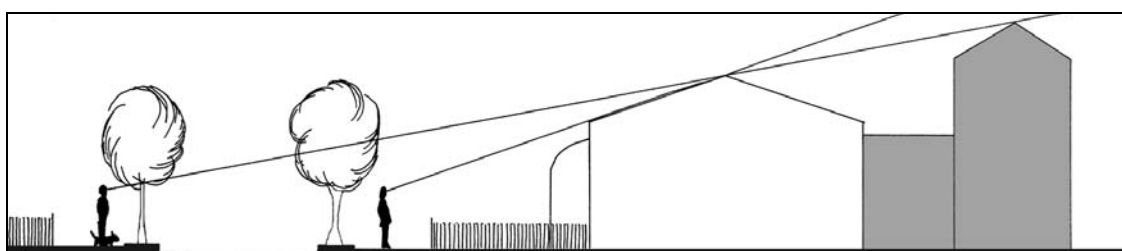

Figure 11: Sight lines drawn to determine visibility of the addition from the street

## ALTERATIONS AND ADDITIONS - SCALE AND MASSING

It is not always possible to add to a dwelling in a way that will not be seen from the street. The design of an addition, which is visible within a heritage area requires careful consideration. It must retain the visual dominance of the significant elements of the property and the significant aspects of the heritage precinct. Additions should be recessive to the significant dwelling and streetscape.

This can be achieved by retaining existing setbacks and working within the building envelope as determined previously.

### Rear additions

A rear addition that is not visible from the street is the preferable option when considering adding to your significant dwelling. It will have less impact on the street elevation of the significant dwelling and the character of the heritage area. This also often allows for a larger scale addition, if the setback means that the existing building screens the impact. (See Figure 11)

### Connection of an addition

Major additions of a size comparable to or greater than, the existing building should be treated as a separate visual entity or should be provided with a visual break between the new and the old section. This can be achieved by using the following methods:

- Set the new wall line back from the existing walls (Figure 12);
- Recess part of the wall or use a change in materials; or
- Create a link building of a smaller scale between the old and the new sections (Figure 13).

It may also be appropriate for the new addition to be lower in height so that it is under projecting eaves of the existing building. (Figure 13)

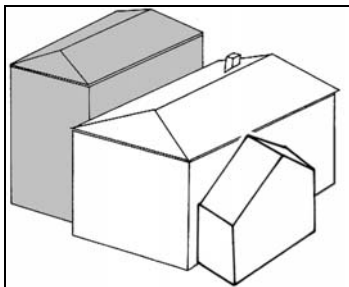

Figure 12: Side setbacks of addition

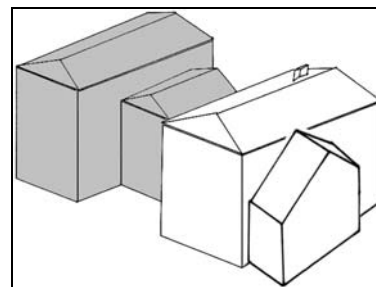

Figure 13: Link to addition

### Side additions

Side setbacks to existing significant dwellings should be retained. Additions to the sides of existing sections of buildings are strongly discouraged. Additions that encroach upon existing side setbacks are only allowable if set well back from the street elevation.

### Roof form of additions

The appropriate roof for an addition depends on the style of the dwelling as well as how visible the addition will be from the street.

Generally the most appropriate roof form for an addition that will be visible from the street is one that matches the existing. The massing however should be smaller. Complex or numerous roof forms to additions should be avoided as they are likely to visually dominate views to the significant streetscape.

The existing roof form and in particular ridgeline visible from the street should not be altered by the addition.



## ALTERATIONS AND ADDITIONS – SECOND STOREY ADDITION

### Adding a second storey

Many traditional styles of dwellings can readily be adapted with an attic storey addition within the existing roof space. Most roofs of 30 degrees pitch or greater should be checked for the capacity to include an attic storey. Federation style houses with their complex roofs are particularly suitable. Where possible, place the attic windows to the side or rear of the dwelling.



Figure 14. Good example of a second storey addition.

If an attic storey is not possible, the addition of a second storey can be appropriate when there is sufficient space to site the addition well back from the street facade with minimal obstruction on the significant fabric of the existing dwelling. A two storey rear addition can often be concealed from view behind the original, single storey frontage of a significant dwelling.

The advantage of an addition hidden to the rear is that it offers greater design freedom. However, care must be taken with the overall form and the materials as often oblique views are available even when most of the bulk is concealed.

### Setbacks

The second floor addition must not dominate the existing building as this will overwhelm and obscure the significance of the building. To achieve this, second storey additions must be sited well back from the street facade. This should also be behind the ridgeline of the main roof form of the existing dwelling.

A setback from the side walls of the existing building is also required as in Figure 12. This creates subservient proportions for the second storey.

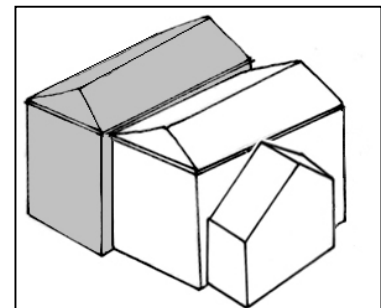

Figure 15: Bad example of an addition with no side setbacks.

Major additions of a size comparable to, or greater than, the existing building should be treated as a separate visual entity. They may be joined by a link as shown in Figure 13.

### Height

There is no specific height recommended for additions to heritage dwellings, as the main concern is minimal visibility from the street. Each case is individual and should take into consideration the following:

- The height and number of storeys of adjacent buildings. The addition should not be higher than adjacent buildings in the street;
- Achieve minimal visibility of the addition from the street by designing within the building envelope determined by sight lines; and
- The roof form of the significant section of the dwelling.

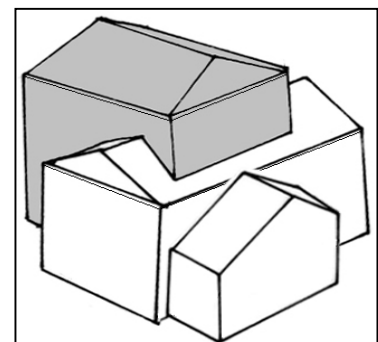

Figure 16: Bad example of an addition that overwhelms the existing significant dwelling.

The following methods could be used to reduce the overall height of your addition and will be considered by Council in assessing your design:

- Set down the floor level of the rear addition by using a concrete slab;
- Use minimal floor to ceiling heights. Ceiling heights can in a lot of cases be lower than in the original section; and
- Provide a raked ceiling line following the roofline to further reduce heights.



### Windows to second storey additions

Provision of windows to the street elevation of a second storey addition is not feasible in most cases. If the windows are to be successful they need to clear the ridgeline of the existing roof. To achieve this the addition will need to be higher and will consequently be more visible from the street. Window proportions required for these situations are often inappropriate. Windows for second storey additions should therefore be accommodated in the rear or side elevations of additions.

---

## ALTERATIONS AND ADDITIONS – DETAILS

---

### Distinguishing Old from New

Generally, there are two main approaches that can be taken to the style of the addition. Firstly, an addition can be in a similar style to the original building but with simplified details so it can be distinguished as new work. Another approach is to design the new work in a contemporary manner that relates to the existing section in terms of location, bulk, form and materials.

In both cases, it is important to distinguish the new work from the existing building. In altering a heritage house, you are adding a chapter to its history. The extension itself needs to be successfully designed, aesthetically and functionally. As an objective, consider that in 50 years, your contemporary design may be conserved as an example of good twenty first century design.

### Materials

Materials and finishes for additions should be compatible with the existing building. It is not always necessary to copy the existing. Most of the buildings in the Churchill Street precinct are constructed of red brick. Tinted or painted render over a lightweight construction is often a good alternative for additions to masonry buildings. Timber or brick can also be used. The compatibility of the material is strongly influenced by the colour of the chosen material and whether the material dominates over the existing dwelling.

Slate roofs are not appropriate on additions as they give a false impression of age. Corrugated iron or colorbond should be used as an appropriate alternative.

### Do not replicate the original

Always avoid replication of heritage elements. Reproduced elements are often incorrect in proportion and materials. They obscure the understanding of the history and age of the place.

Simple detailing to the addition is encouraged so it does not detract from significant elements of the existing building.

### Windows and openings

New openings in existing facades visible to the street are generally to be avoided.

The windows and openings for additions and alterations visible from the street should have similar proportions to the existing significant windows. They should suit the style of the building and should be constructed in similar materials. The detailing of new windows should however be simpler to distinguish them from the originals.

Large areas of glass are generally inappropriate and should be broken into groups of traditional sized windows. The use of reflective glass should be avoided.

### Reinstatement of original details/elements

Original elements or details such as a verandah or valence should only be reinstated if there is sufficient evidence to do so accurately. If reinstatement is to occur the same quality of materials as the original should be used. The date of the reinstatement should be discretely placed on the reconstructed element.

### Exterior painting

Colour schemes for heritage dwellings should relate to the period and style of construction and the character of the streetscape and heritage area. Most paint suppliers now provide a *Heritage* range of colours and can provide assistance in choice of schemes.

It is not the colour that is necessarily the most important consideration, but the placement of the colours. Always obtain paint samples so you can look at the colours together and against your dwelling.

In the Churchill Street precinct most of the houses are face brick with timber or render detailing. Previously unpainted surfaces should not be painted.

Where possible reinstate early paint schemes.

Talk to the Whitehorse Heritage Advisor if you are unsure of appropriate colour schemes. A permit may be required for painting your house if your property is individually listed in the Heritage Overlay. Talk to a planner to determine whether this is required.

### Paint removal

- Do not sandblast as a method of paint removal. Use a non-abrasive method of removal undertaken by experienced contractors.

## ALTERATIONS AND ADDITIONS – GARAGES, FENCES AND GARDENS

### Carports/Garages

Carports and garages, although often open structures, can have a substantial visual impact on existing dwellings. Retention of original carports/garages is encouraged.

Location of carport/garages in the front setback of dwellings is not favoured (Figure 18). All options for location of parking at the rear or side of properties should be explored. If locating the carport/garage at the side of property they should be setback from the front facade by at least two metres.

Position carports/garages at the rear of properties if possible, utilising lane ways or side street access.

Avoid attaching the carport/garage to the dwelling and ensure that it appears as a separate visual entity. Continuing an existing wall without a break or change of materials to form a garage is not acceptable.

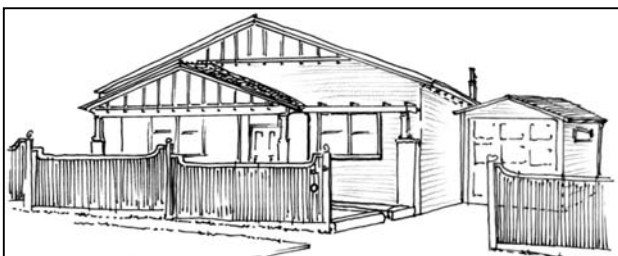

Figure 17: good example of a garage

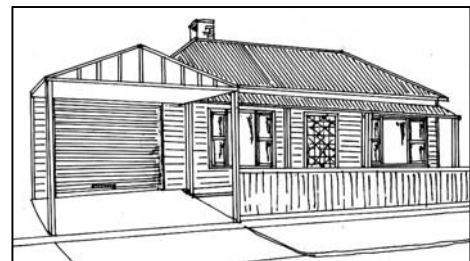

Figure 18: bad example of a garage

The carport/garage should be of a simple design so as not to dominate the street facade. As a general rule they should be at a smaller scale than the dwelling and should not contain elaborate ornamentation. As is the case with additions, do not copy decorative details from the dwelling as this detracts from the significance. Double garages are not favoured due to their size and bulk. Where doors are required use tilt up timber faced doors. Roller doors require greater heights, and the materials are not compatible with most heritage dwellings.

## CHURCHILL STREET PRECINCT

### Fences

Research the existing fence and establish its age or whether it is the original fence. Retain as much of the original fabric as possible. It is better to have an original and worn looking fence, which is maintained in working condition than to have a brand new replica.

In the Churchill Street precinct many of the fences are individually designed to suit the style and features of the residence. This tradition should continue, with regard to the other considerations outlined below.



Figure 19: bad example of a fence

### Recreating a previous fence

Only recreate a previous fence if there is enough evidence of its original appearance and if it is to be recreated accurately. This includes using the same quality materials as previously used.

### Building a new fence

Build a new fence appropriate to the style of the heritage dwelling and surrounding properties if it is needed. Research the range of fence types appropriate to the style of your dwelling. Refer to the style guide in these guidelines. Use technical references such as *Fences and Gates c.1840-1925*, *National Trust Technical Bulletin 8.1* or talk to your Heritage Advisor for advice on a suitable design.

New fences should retain heights, the relation of solid to opening and materials consistent with the street.

The new fence should be stylistically accurate in proportioning and materials but replication of historical detailing is not appropriate. Individual details can be incorporated to make the fence special.

High solid fences are not acceptable as they can dramatically change the streetscape character by limiting views and altering characteristic street lines established by repetition of existing fence heights. Fences in conservation areas are rarely over 1300mm in height and no new fences should be over this height.

Fence colours should suit the style of the dwelling and be in keeping with the streetscape.

### Gardens

Additions and new works should respect historic trees, plantings and historic garden layouts through siting proposed new development at a distance that ensures the ongoing health of the tree or planting and does not negatively impact upon an historic garden layout or context.

Many properties in the Churchill Street precinct contain garden features constructed at a significant time or for a significant reason. These should be considered as important heritage structures and treated with care as they contribute to the significance of the property.

## ALTERATIONS AND ADDITIONS – DEMOLITION & SUBDIVISION

### Demolition

A permit for demolition of a Heritage place (or part thereof) subject to the Heritage Overlay will not be supported unless:

- The heritage place (or part of) has no heritage value and/or
- The heritage place (or part of) has been changed beyond recognition of its original or subsequent contributory architectural character; and
- The heritage place (or part of) does not contribute to the character of the streetscape; and
- the heritage place (or part of) does not form part of a group of similar buildings, historic streetscape or collection of historic buildings.

A heritage building's derelict state is not, in itself a case for demolition.

Regardless of whether the building is contributory, it should be appraised for opportunities and constraints it brings to the site. Consider the merits of the existing structure and whether it can be recycled successfully. It is a waste of energy, in terms of materials and labour to unnecessarily demolish a building available for recycling.

### Subdivision / Multi-Dwelling Development

Subdivision on large sites heritage precincts is allowable when the visual setting of the significant building can be retained. It is often the impact of the infill building rather than the subdivision itself which may impact on the significance of the heritage place or area.

The subdivision of a site should conserve the setting of the place providing sufficient space to retain garden areas, buildings and other features essential to the character, importance and integrity of the significant property.

If subdivision is to occur consideration should be given to the following:

- The pattern of subdivision shall conserve the setting of the heritage building, providing sufficient space to retain garden areas, buildings and other features essential to the character, importance and integrity of the significant property.
- Subdivision should not obstruct or dominate significant views to and from the heritage place and precinct.
- The heritage place should retain visual prominence over potential development on the subdivided land.

The example in Figure 20 demonstrates the retention of a significant outbuilding, which is associated with the heritage building, and the construction of infill to the rear of this. It also demonstrates the use of a rear lane for vehicle access to the new building avoiding the construction of a new street crossover.

Council also has additional requirements for subdivision or multi-dwelling developments. You should discuss any application with one of the planning officers.

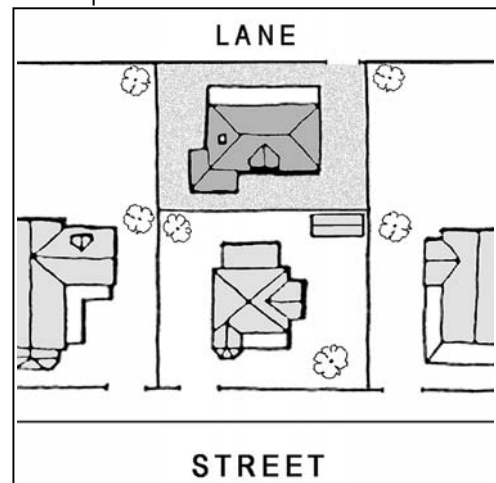

Figure 20: good example of subdivision & infill, retaining setting of existing building.

### Design of buildings on subdivided land

All applications for subdivision involving protected land should be accompanied by design guidelines that include proposals for building envelopes, materials colours and fences for the subdivided lots.

The design of the building at the rear of a property should address similar design considerations as if undertaking a rear extension. The main consideration is to minimise the visibility of the new building to the street as well as not losing any heritage qualities in the laneway.

It is not always possible to add to a building to the rear in a way that it will not be seen from the street. In these cases the design of the infill must be subservient to the significant elements of the property and the significant aspects of the heritage area.

In addition to Figure 21 below refer to the alterations and additions – visibility section of these guidelines for information on determining view lines and design of rear additions.

As with additions and alterations to a significant building, a new building should be recognisable as a product of its time and not create a false impression of age or an earlier style.

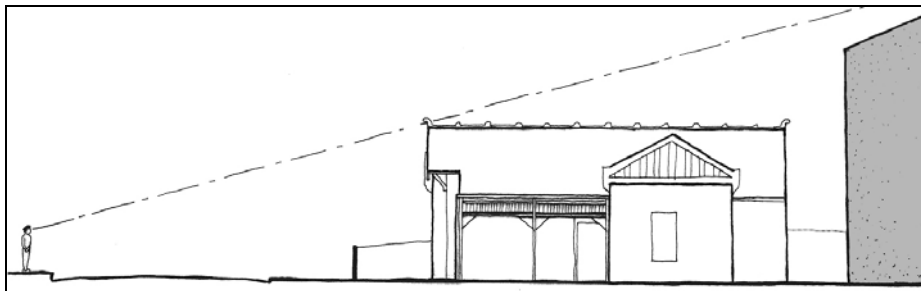

Figure 21: Sight lines drawn to determine visibility of rear infill from the street.

## ALTERATIONS AND ADDITIONS – INFILL

A new infill building may be required within the heritage precinct if demolition of a non-contributory building has been allowed or if an empty site exists.

Good and sensitive design of new buildings in heritage areas is essential for retaining the heritage streetscape character of heritage precincts in Whitehorse. Good design is essentially about designing in context and having regard to the site and its surroundings. Consideration should be given to the nature of adjoining and surrounding buildings and the overall significance and character of the heritage area.

A site analysis should be undertaken as part of an application and should demonstrate an understanding of the significance, character and setting of the surrounding area. The design for the infill should be a response to this analysis.

The design of new buildings in heritage areas should consider the following:

### Setbacks

To retain the character of the area the setbacks and orientation of existing streetscapes should be retained. This is especially important for buildings facing the street. Side setbacks, and setbacks to laneways should be respected as well as street setbacks.

---

### Form, massing and height

New buildings should be recessive and never visually dominate or obscure views to contributory buildings in the streetscape.

The form, massing, height and bulk of the infill building should reflect the predominant height and proportions of adjacent buildings in the street.

### Street patterning

The proportions and spacing of door and window openings should relate to those of adjoining historic buildings and the surrounding heritage place. Their general shape should match characteristics of heritage buildings.

### Materials and finishes

Materials and finishes should be compatible to existing buildings in the streetscape to ensure that the infill building does not stand out. In the Churchill Street precinct the houses are generally brick and therefore a brick building would be the most appropriate infill. An alternative to this is the use of render over a lightweight type of construction.

### Details

Reproduction of period detailing on new infill buildings such as cast iron lacework and timber decoration to gables is inappropriate. Contemporary detailing, however, which is sympathetic to other buildings in the street is encouraged.

As with additions and alterations to a significant building, a new building should be recognisable as a product of its time and not create a false impression of age or a style.

### Garages

In most of the City of Whitehorse heritage areas, carports and garages are not traditional street elements. For this reason, carports or garages should not be dominant elements in infill development. Location of garages in front of the dwelling or incorporated into the dwelling should be avoided as there is little opportunity to articulate a garage to respect the street patterning.



---

## OWNERS CHECKLIST FOR DESIGN OF ALTERATIONS/ADDITIONS

---

- Visit Council, talk to a Planner.
- Determine whether your dwelling is of individual significance.
- Identify the cultural heritage significance of the dwelling, street and area.
- Undertake a site analysis to be submitted with the application.
- Explore alternatives.
- Meet with Heritage Advisor to discuss ideas.
- Roughly sketch some alternatives.
- Is further advice needed from the Advisor?
- Draw up plans for addition/alterations and include your analysis of heritage issues.
- Submit Application to Council.

### **Additional documents required if your planning application is heritage related**

- Existing conditions, plan and elevations.
- Photos of existing conditions.
- Streetscape elevations with addition shown and at least two properties either side.
- Provide certificate of title/Covenant declaration.
- Elevations showing heights, materials, colours
- Plans showing location of addition and setbacks (plans should all be dimensioned)
- Sketches of sight lines to the additions.

### **Planners checklist for assessment of alterations/additions**

- Does it dominate original dwelling or streetscape?
- Original elements not altered or removed?
- Simplified details?
- New distinguishable from old?
- Sympathetic in form, scale and materials to the significant building?
- Sight lines, side and elevation provided?
- Evidence of alternatives explored? (Eg. is rear addition possible rather than second storey).
- No replication of details?
- Setbacks from side of existing dwelling?
- Fence appropriate?
- Colour scheme appropriate?
- Carport/garage appropriate?
- If reinstating elements, has enough evidence of the original been provided?